

DESCRIPTION

The Recordall[®] series is a positive displacement meter. The series is best suited for metering fluids up to a viscosity of 700 mPas and at an operating temperature of 50°C up to 120°C.

APPLICATIONS

Clean and moderately dirty liquids, hard and demineralized water, oils, fuel, solvents, etc.

DESIGN

The metering chamber includes disc, positioning bar and transmission magnet. The chamber is inserted into the meter body. A screen in the inlet side of the body protects the chamber against penetration of larger solid particles.



FEATURES

- Magnetic coupling
- Compatible with many liquids
- Wide flow range
- Low pressure loss
- Low weight
- High durability, accuracy
- Low-cost
- Modular system
- Protection class IP 65

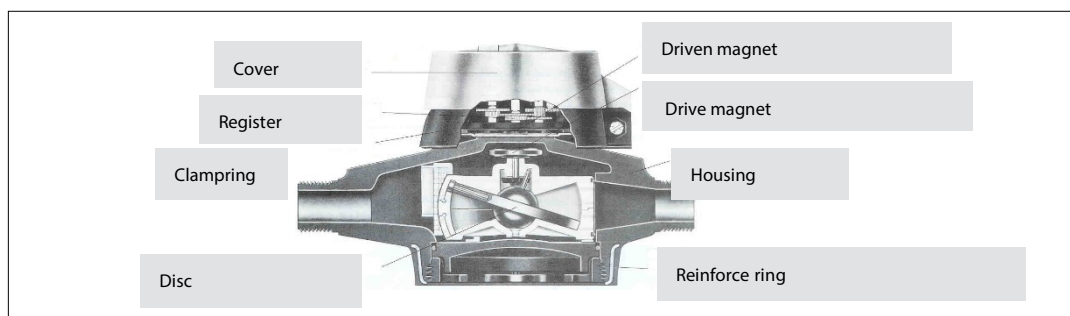

WORKING PRINCIPAL

The top and lower part of the meter chamber are spherical shaped. A ball bearing centralizes the disc between the two spherical cups. A nutating motion of the disc is generated when flow enters the meter chamber. Complete separation between inlet and outlet chamber volumes is always

achieved by one dedicated disc diameter line. The inlet and outlet parts of the meter chamber are separated by a partition plate. The positioning bar forces the disc to nutate around the center axis of the chamber thus driving the transmission magnet.

DIMENSIONS (MM)

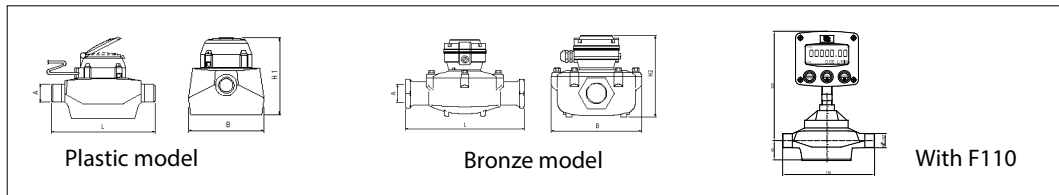

Type	M 25			M 35	M 40		M 70	M 120	M 170
	Plastic	Bronze	Stainless steel	Bronze	Plastic	Stainless steel	Bronze	Bronze	Bronze
Connection A	R 3/4" / 1"	R 3/4" / 1"	1"	R 1"	R 1 - 1/4"	1 1/4"	R 1 - 1/4"	1 - 1/2" NPT	2" NPT
Lay length L	190	190	190	230	270	230	270	321	387
Width B	122	122	135	133	151	135	184	223	240
Height register H 1	125	125	130	132	150	130	165	178	204
Height transmitter H 2	128	128	155	168	180	155	200	213	239
Height F110	265	265	265	270	290	265	310	323	349

PRESSURE DROP

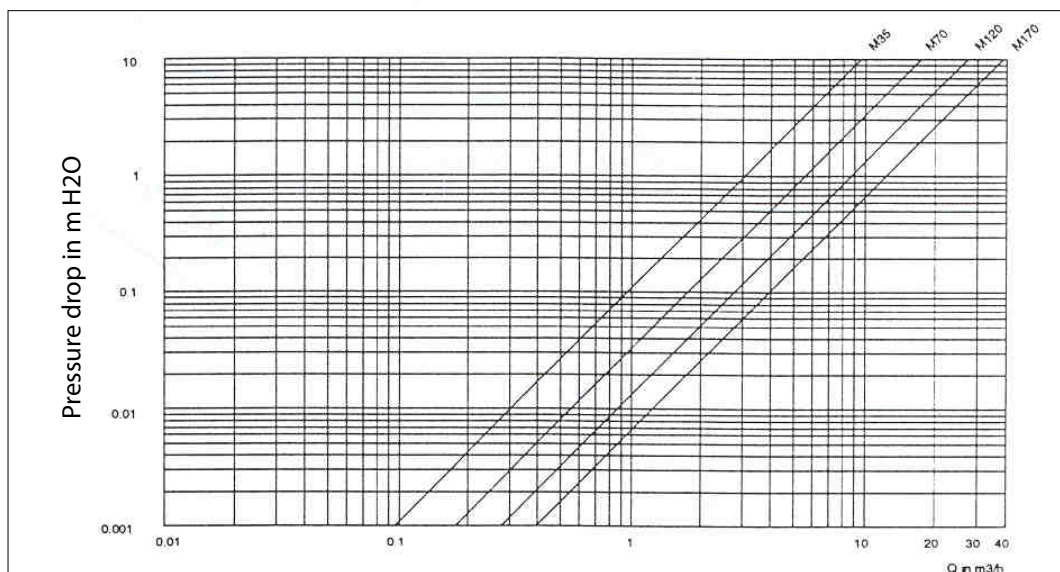

TECHNICAL DATA

Type	M 25			M 35	M 40		M 70	M 120	M 170
	Plastic	Bronze	Stainless steel	Bronze	Plastic	Stainless steel	Bronze	Bronze	Bronze
Size DN	15 / 20	15 / 20	20	20	25	25	25	40	50
Nominal pressure PN	16	16	16	16	16	16	16	16	16
Max. Temperature (PPO)	50°C	50°C	50°C	50°C	50°C	50°C	50°C	50°C	50°C
Max. temperature (Vectra)	-	120°C	120°C	-	-	-	120°C	120°C	-
Flow range l/min (PPO)	1 – 100	1 – 100	1 – 100	2 – 132	2 – 160	2 – 160	4 – 265	8 – 454	8 – 643
Flow range l/min (Vectra)	-	3 - 100	3 – 100	-	-	-	19 – 265	18 – 454	-
Accuracy (1:10)	±0,5 %								
Accuracy (flow range)	±1.5 %								
Weight	1.2 kg	1.8 kg	5.8 kg	2.7 kg	1.8 kg	7 kg	5.5 kg	10.5 kg	13.6 kg

MATERIALS

Type	M 25				M 35		M 40		M 70		M 120		M 170	
Housing	Nylon	Bronze	Nickel coated Bronze	SS 1.4571	Bronze	Nickel coated	Polycarbonate	SS 1.4571	Bronze	Nickel coated	Bronze	Nickel coated	Bronze	Nickel coated
Measuring chamber	PPO	PPO / Vectra			PPO	PPO / Vectra	PPO		PPO / Vectra		PPO / Vectra		PPO	PPO
O-rings	Buna	Buna / Viton			Buna	Buna / Viton	Buna		Buna / Viton		Buna / Viton		Buna	Buna
Retainer strap (PPO)	Nylon													
Retainer strap (Vectra)	Stainless steel 316				PPO				Stainless steel 316					
Screen	PPO													
Bottom (PPO)	Nylon	Cast iron	Cast iron/ Nickel coated	SS	Cast iron	Cast iron/ Nickel coated	Polycarbonate	SS	Cast iron	Cast iron/ Nickel coated	Cast iron	Cast iron/ Nickel coated	Cast iron	Cast iron/ Nickel coated
Bottom (Vectra)	-	Bronze	Bronze Nickel coated	SS	-	Bronze Nickel coated	-	SS	Bronze	Bronze Nickel coated	Bronze	Bronze Nickel coated	-	Bronze Nickel coated
Retainer ring	Nylon	-	-	-	-	-	Polycarbonate	-	-	-	-	-	-	-
Magnet	Bariumferrit													
Crossbar	Nylon													
Thrust roller	Nylon													
Roller insert	Stainless steel 316 / 316 S/S													

F-SERIES (F012, F018, F110, F131)



INPUT FEATURES

With the F-series, the following signals types can be processed:

- Flow measurement: Turbine sine wave (coil) pick-ups, reed switches, hall-effect sensors and other active or passive NPN/PNP pulse signals, NAMUR sensors and 2 or 3 wire (0)4 – 20 mA or 0 – 10 V DC.
- Temperature measurement: 2, 3 or 4 wire PT100 (PRTD) elements, thermocouple as well as 2 or 3 wire (0)4 – 20 mA or 0 – 10 V DC signals. Linearization of the input signal, data filter functions and square root calculation are all available to process the input signals.

MODELS

F012 Display with external power supply or battery powered

F018 Alarm or pulse output, analog output with HART communication

F110 Pulse output, analog output, optional RS232/RS485

F131 Batch controller with pulse output, analog output, 2 batching outputs, optional RS232/RS485

OPTIONS FOR HAZARDOUS AREA INSTALLATION

The F1-series can be supplied with certified intrinsically safe to ATEX and IECEx.

The basic F0-series have got the following certifications with an ambient temperature of -40°C to +70°C (-40°F to +158°F).

• The ATEX markings for gas and dust applications are:

II 1 G Ex ia IIC T4

II 1 D Ex iaD 20 IP 65/67 T 100°C.

OUTPUT FEATURES

Related to the functionality of the selected model, the following output features are available:

- Analog output proportional to the flow rate. The active, passive or isolated (0)4 - 20mA or 0 - 10V DC analog output can also be used to control actuators with the PI(D) controllers.
- Transistor or relay outputs for high and low alarms, scaled pulse output, flow-direction as well as the control of valves/relays in batch and level control applications.
- The RS232, RS485 or TTL interface makes it possible to communicate remotely, even with the battery-powered unit.

All software parameters can be monitored and modified in addition to the usual transfer of data using the Modbus protocol.

FLOW MONITOR ER-500



FEATURES

Compact size

- High accuracy and repeatability (0.05 %)
- Flexibility of installation options
- Robust alarm parameters provide faster warning when something changes in the process or pipeline.
- Advanced connectivity options allow you to connect meters to your network for remote monitoring and process automation capabilities.
- Flexible power options include battery and 4-20 mA loop power, providing a number of benefits including: The ability to install in remote location and be up and running immediately.
- Maintains readings and settings in the event of a power loss, and prolong the life of the batteries for up to 6 years.
- An updated display and enhanced totalization options provide more flow information at your fingertips, including display of rate and total at the same time and standard, batch and grand totals.

INPUT

Frequency range	1 to 3500 Hz
Frequency accuracy	± 0.1 %
Over voltage protection	28V DC Frequency range

OUTPUT

Analog: 4-20 mA

TOTALIZING PULSE

Optoisolated (ISO) open collector transistor, non-isolated open drain FET.

STATUS ALARMS

Open collector transistor, adjustable flow rate with programmable dead band and phase.

MODBUS

Modbus RTU over RS485, 127 addressable units / 2-wire network, 9600 baud, long integer and single precision IEEE754 formats; retrieve: flow rate, job totalizer, grand totalizer, alarm status and battery level; write: reset job totalizer, reset grand totalizer

PROTECTION CLASS

NEMA 4X/IP 66

More information you get in the data sheet "Flow monitor ER-500".

REGISTER

Typ ILR 701, 750



FEATURES

- Large six digit LCD display
- Display in liters, pints, quarts or gallons, freely programmable
- 11 digits, non-resettable lifetime totalizer and 6 digits, resettable totalizer
- ILR series: -20 °C to +80 °C (-4 °F to +140 °F)
- Replaceable long life battery
- Calibration factor saved in non-volatile memory
- 9 point linearization (ILR 750, ILR 701)
- Scalable pulse output (ILR 750)
- 4-20 mA output (ILR 750)
- Protection class IP65

DESCRIPTION

The electronic register module contains a microprocessor board powered by a lithium battery. It can be programmed to batch in liters, pints, quarts, or gallons and will totalize in liters or gallons. A calibration factor and unit of measure are programmed during factory test. Unlike mechanical registers, these units can be electronically recalibrated in the field when necessary. A 6-digit LC display, accurate to three decimal places, shows the exact amount of fluid that has passed through the meter. The entire register module is protected from normal wear and tear by a rugged, shock resistant housing.

OPERATION

The nutating disc meter has magnets on the gears that cause the reed switches to send pulses to the register as they rotate.

The register is in a sleep mode until it detects these pulses caused by fluid going through the meter. The micro-processor in the register then measures the flow and will display either the batch totalization or the flow rate of the

fluid going through the meter on the 6-digit display. The registers batch totalizer is a 6-digit display with three places of resolution after the decimal point. If the total dispensed exceeds 999.999 then the display will shift and only 2 digits will be displayed after the decimal point, 9999.99 and will continue to shift to the maximum value of 999999. After reaching 999999 the batch totalizer will rollover to 0.000. The batch totalizer is reset to zero when the reset button is depressed.

The register also has a resettable totalizer that requires that the total and reset button both be depressed to reset (hold the "Total" button, then press the "Reset" button to reset this totalizer while resettable totalize is displayed). This would be used for multiple batch totalization purposes.

The register's life time totalizer is 11 digits and will either be in gallons or liters based on the unit of measure selected. Pushing and holding the total button while the life time totalizer is displayed will display the full 11-digit life time totalizer value.

	Register features
ILR 701	Flow rate or totalizer display selectable in the programming menu Selectable unit of measure 9 point linearization
ILR 750 pulse output + 4-20mA output	Scalable pulse output Ability to set pulse output length Analog 4-20mA output representing the flow rate of the meter Minimum and maximum values can be set for analog output 9 point linearization

REEDSWITCH PULSE TRANSMITTER TYPE PFT-2 / OGT



FEATURES

- Reed switch unscaled
- Cost effective

DESCRIPTION

The pulse transmitter PFT-2 supplies pulses through a reed switch, which is free of potential.

PULSE TABLE

Meter type	DN	Size	PPL	PPG
RCDL M25	20	5/8"	52.4	198.3
RCDL M35	20	3/4"	33.5	126.7
RCDL M40	25	1"	23.7	89.8
RCDL M70	25	1"	12.3	46.8
RCDL M120	40	1½"	6.3	23.9
RCDL M170	50	2"	3.8	14.6

TECHNICAL DATA

Life expectancy of reed switch	Up to 5x10 ⁸ switch closures, depending on load
Switch load	10 W, 12 VA, 0.5 A max.
Fluid temperature	220 VDC max.
Protection class	120 °C
Housing	IP 65 / IP42 (OGT)

WIRING DIAGRAM

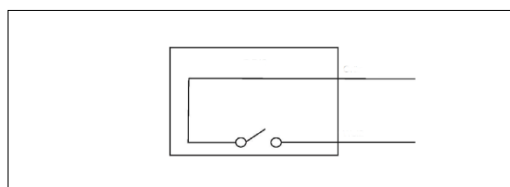

ELECTRONIC PULSE TRANSMITTER TYPE PFT-2E

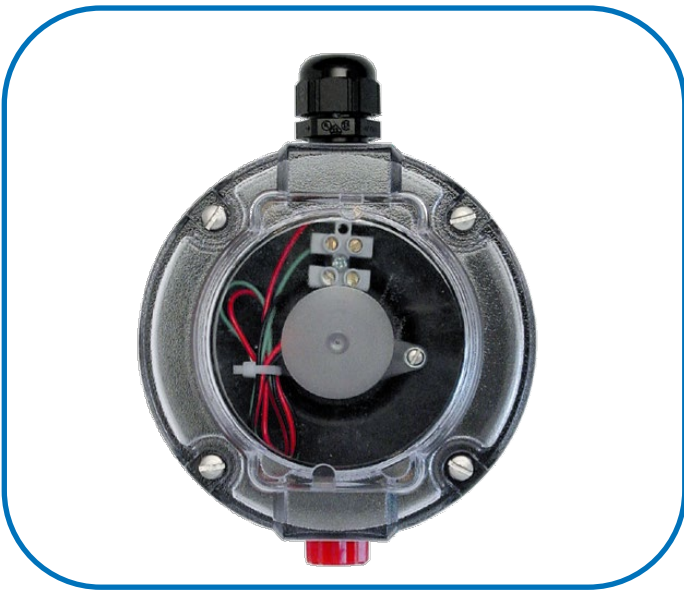

Technical data	
Power supply	6 – 24 VDC
Current consumption	13.5 mA max.
Output Max. current	Open collector NPN20 mA
Fluid temperature	120 °C
Protection class	IP 65
Housing	High impact reinforced nylon

Meter type	Size	PPL
M25	20	52.4
M40	25	23.7
M70	25	12.3
M120	40	6.3
M170	50	3.8
OP15	15	58.9
OP25	25	20.3
OP50	50	5.4

DESCRIPTION

A magnetoresistive sensor generates unscaled pulses, supplied by an open collector.

DIMENSIONS (MM)

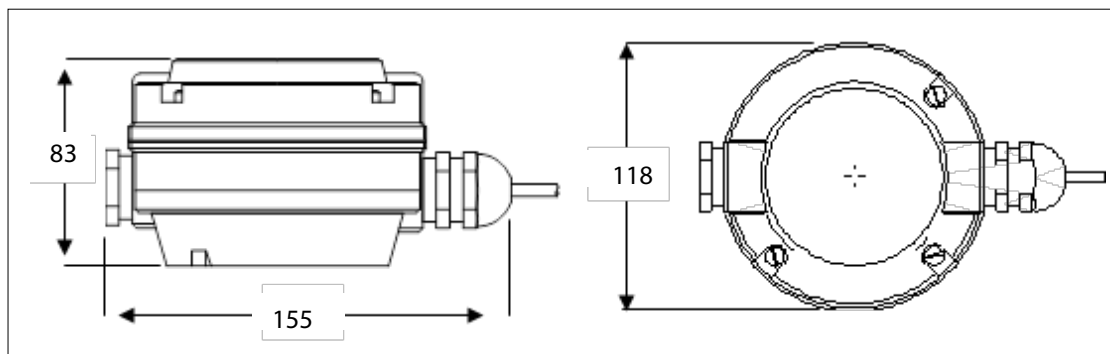

PULSE TRANSMITTERS PM5 AND PM5-ILR FOR RCDL METERS



DESCRIPTION

The pulse transmitter type PM5 supplies pulses through a reed switch, which is free of potential. The PM5-ILR offers the same function and has an additional display with flow rate and/or totalizer.

FEATURES

- Scalable reed switch
- Optional display (PM5-ILR)

TECHNICAL DATA

Life expectancy of reed switch	up to 5x10 ⁸ switch closures, depending on load
Switch load	10 W, 12 VA, 0.5 A max. 220 VDC/VAC max.
Fluid temperature	120 °C for PM 5
Protection class	120 °C for PM 5-ILR
Life expectancy of battery	IP 65

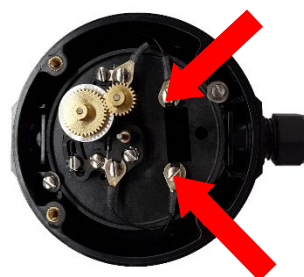

MODELS



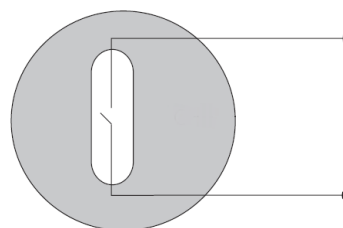

PM5	Pulse output
PM5-ILR	Resettable totalizer of flow rate programmable, format xxxx.x L, PT, QT, GAL



PULSE RESOLUTION (PULSE/LITER)

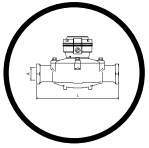

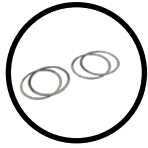
Meter type	Pulse transmitter			
	PM5 & PM5-ILR			
	0,1	1	10	100
RCDL M25	---	x	x	x
RCDL M35	---	x	x	x
RCDL M40	x	x	x	---
RCDL M70	x	x	x	---
RCDL M120	x	x	x	---
RCDL M170	x	x	x	---
Other pulse resolutions are possible on request.				

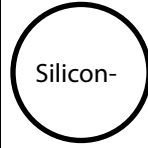
ORDER MATRIX

	Housing material	Housing dimension	Measuring chamber material	O-rings material	Connection (specify only for M25)	Register	Additional features
RCDL –							
	BR	M25	PPO	Buna	3/4"	ILR701	SIL
	BRN	M35	Vec	Vit	1"	ILR740	
	SS	M40		EPDM		ILR750	
		M70		FEB		RZW10	
		M120				RZW100	
		M170				F110 A*	

ATEX SENSOR

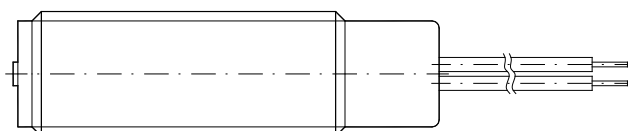
NPN / PNP

White ()

Red (+)

Black (-)

TECHNICAL DATA

Switching function	Open collector
Output type	NPN or PNP 3-wire (2 versions available)
Supply voltage	5-30 VDC ($I \leq 15$ mA)
Supply current	100 mA max ($P_{max} = 0.66$ watt)
Effective internal inductivity	$C_i \leq 12$ nF
Effective internal inductance	$L_i \leq 0$ μ H
Cable length	3 meters
Material	Stainless steel 1.4404 (316L)
Protection class	IP66 / IP67

MARKING

USA	Intrinsically safe Class I, II, III, Division 1 GROUP ABCDEFG T6 to T5 Class I, Zone 0, AEx ia IIC T6 to T5
Canada	Intrinsically safe Class I, Division 1 GROUP ABCD T6 to T5 Class I, Zone 0, Ex ia IIC T6 to T5
ATEX	Ex II 1G Ex ia IIC T6 bis T4 Ga
IECEX	Ex ia IIC T6 to T4 Ga

NAMUR SENSOR

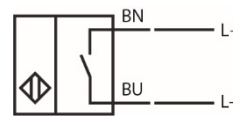
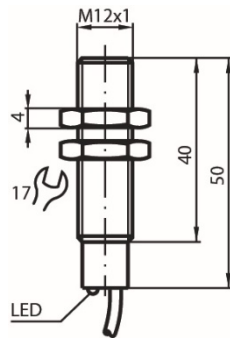

TECHNICAL DATA

Switching function	Normally open (NO)
Output type	NAMUR 2-wire
Nominal voltage	U _o 8.2 V (R _i ca. 1 kΩ)
Effective internal inductivity	C _i ≤ 15 nF; a cable length of 10 m is considered
Effective internal inductance	L _i ≤ 35 μH; a cable length of 10 m is considered
Switch state indicator	LED (yellow)
Ambient temperature	-25 to 70°C (-13 to 158°F)
Cable length	2 meters (PVC)
Core cross-section	0.34 mm ²
Material	Stainless steel 1.4404 (316L)
Protection class	IP66 / IP67

MARKING

Namur	CE 0102 / Ex II2G Ex ib IIC T6 Gb
--------------	-----------------------------------