

GEA Hilge HYGIA H

The new high-pressure pump range

GEA Hilge HYGIA H

High-end centrifugal pump engineered for system pressures up to 64 bar.

The GEA Hilge HYGIA H as a part of the GEA VARIPUMP line is an additional range to the pump portfolio of single-stage end-suction centrifugal pumps. The high-pressure pump is designed for system pressures up to 64 bar, available in two sizes and

suitable for the use in industries with high demands to hygiene and reliability. A typical application area for the new high-pressure pump is membrane filtration like Reverse Osmosis (RO) and Nano Filtration (NF) in the dairy, food and beverage industry.

PERFORMANCE CURVE 50 HZ

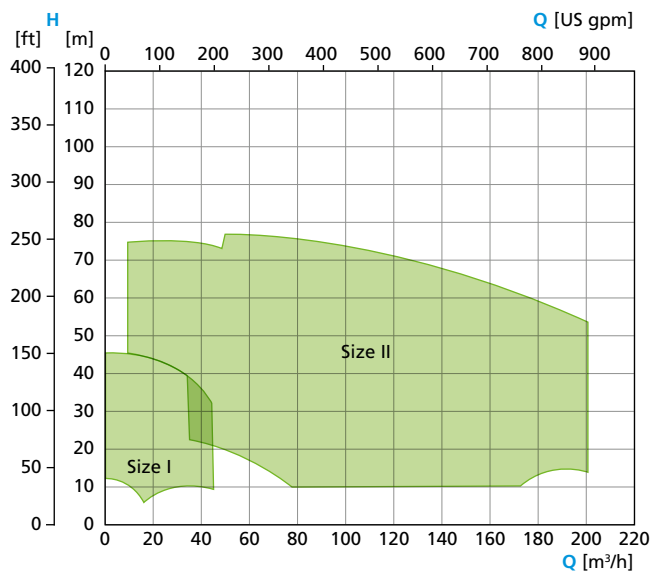

PERFORMANCE CURVE 60 HZ

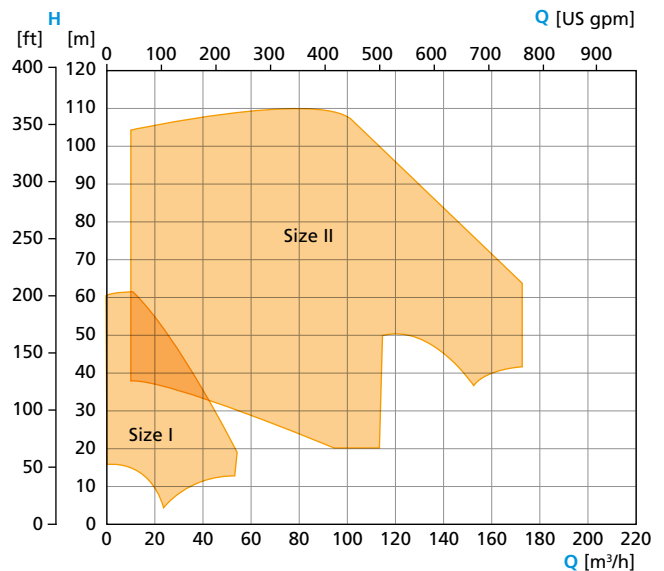

MEMBRANE FILTRATION

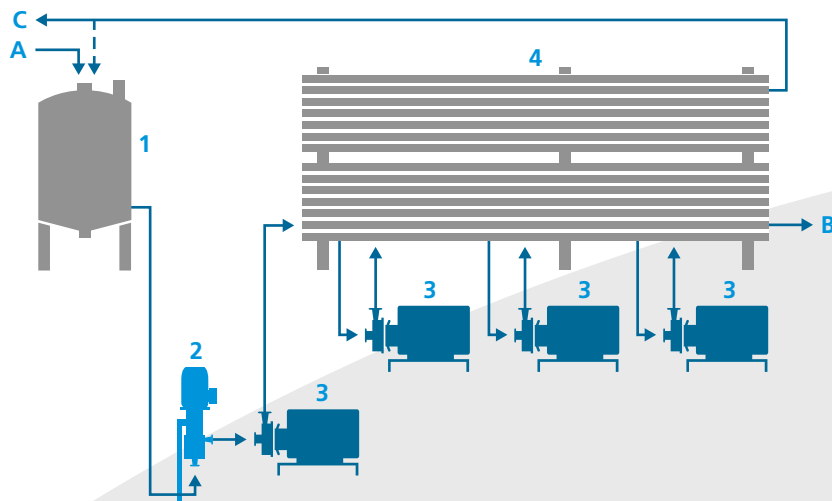

- 1 Feed/buffer tank
 - 2 Feed pump (GEA Hilge CONTRA)
 - 3 Loop pump (High-pressure pump GEA Hilge HYGIA H)
 - 4 Membrane filtration loops
- A Whey/milk
 - B Concentrate/retentate
 - C Filtrate/permeate

With high pressure into the dairy industry

The new high-pressure pump from GEA is based on the GEA Hilge HYGIA which has proven itself over decades. The premium pump has always stood for good cleanability, high stability and quality. Now the series can also cover the high pressure ranges that are required for membrane filtration in the whey process.

Corresponds to the highest global hygiene requirements

Produced of high-quality materials that meet the strictest global hygiene standards, GEA Hilge HYGIA H also offers maximum flexibility. The pumps are equipped with operating-point-optimized impellers.

Suitable for the highest standards

The materials used for GEA Hilge HYGIA H pumps have been selected for the use in hygienic processes. The housings are made of CrNiMo (1.4404) forged and have a smooth surface without pores and blowholes.

Certification-compliant

GEA Hilge HYGIA H pumps are CIP/SIP-able conforming to the performance criteria for pumps acc. to DIN EN 12462. The media-contacting parts meet the requirements of the QHD- and 3-A standards.

Your advantages at a glance:

- Designed for system pressures up to 64 bar
- Available in two sizes, with a flow rate of up to 200 m³/h and a maximum pump head of 72 m (50 Hz)
- Capable of pumping a wide range of liquids
- High surface quality and maximum reliability for hygienic operation
- Complies with the highest hygiene standards (3-A)
- High reliability leads to better plant availability
- Proven HYGIA design over decades
- Competent pump experts support during the whole life cycle process

TECHNICAL DATA

GEA Hilge HYGIA H	50 Hz	60 Hz
Max. flow rate	200 m ³ /h	175 m ³ /h
Max. pump head	72 m	105 m
Operating temperature	up to 100 °C	
Sterilization temperature	up to 140 °C (SIP)	
Max. system pressure	PN 64	

FEATURES AND BENEFITS

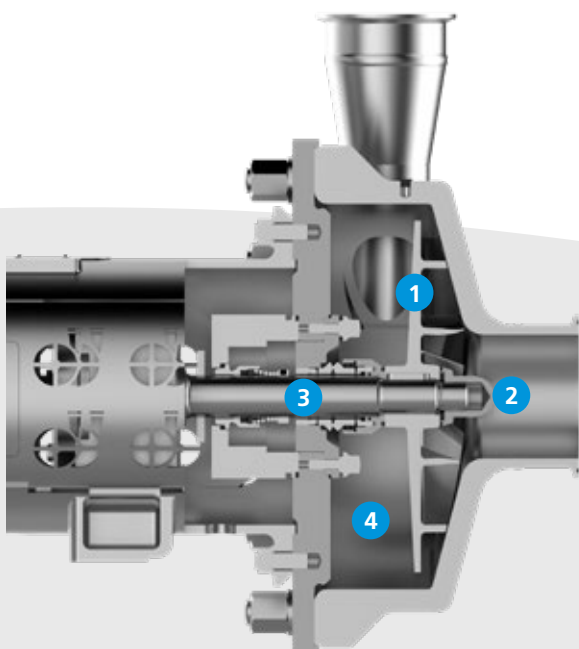

1 Optimized impeller

The pumps are equipped with operating-point-optimized impellers

2 Hygienic construction

The constructional design allows optimal cleaning (CIP) and sterilization (SIP)

3 In-line mechanical seal

The front-loaded mechanical seals are easy to change and allow effective cleaning, cooling and lubrication

4 Dead-end-free design

The pumps meet the highest hygienic demands to avoid contamination



We live our values.

Excellence • Passion • Integrity • Responsibility • GEA-versity

GEA is a global technology company with multi-billion euro sales operations in more than 50 countries. Founded in 1881 the company is one of the largest providers of innovative equipment and process technology. GEA is listed in the STOXX® Europe 600 Index. In addition, the company is included in selected MSCI Global Sustainability Indexes.

GEA Germany

GEA Hilge

Niederlassung der GEA Tuchenhagen GmbH

Hilgestraße 37–47

55294 Bodenheim, Germany

Tel +49 6135 7016-0

Fax +49 6135 1737

sales.germany@gea.com

gea.com